

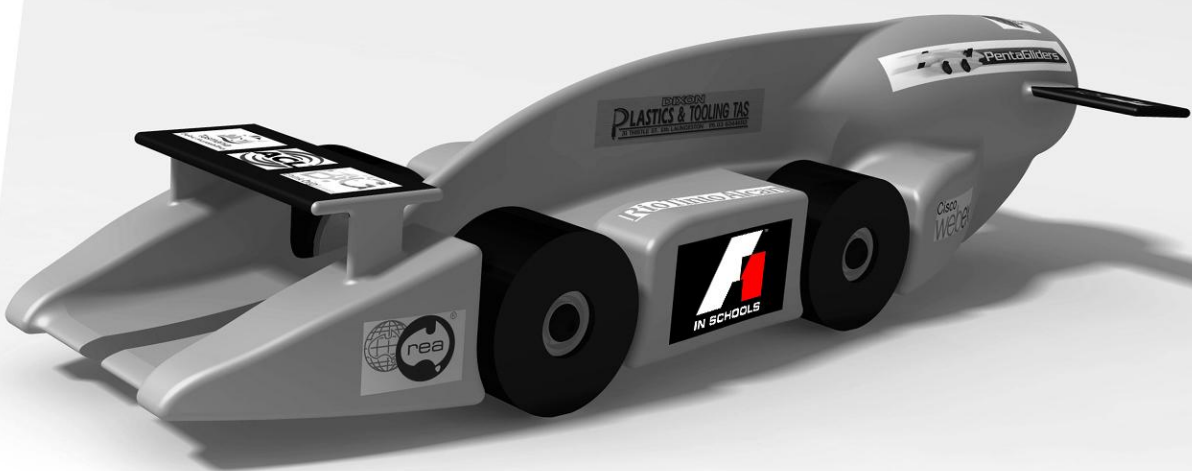

THE FORMULA ONE™ TECHNOLOGY CHALLENGE

2012 WORLD FINALS Technical Regulations



Refer also to the 2012 World Finals Competition Regulations

Front Cover - PentaGliders World Champions F1 Car, Brooks High School. Australia.

Amendments made on, (date to be inserted here), will be indicated thus (using red underlined text).

CONTENTS

| | |
|--|-----------|
| PREFACE – SUMMARY OF REVISIONS FOLLOWING 2011 REVIEW..... | 4 |
| ARTICLE T1 – DEFINITIONS..... | 5 |
| T1.1 F1 in Schools car..... | 5 |
| T1.2 Fully assembled car..... | 5 |
| T1.3 Body..... | 5 |
| T1.4 CO2 cylinder chamber..... | 6 |
| T1.5 Wing..... | 6 |
| T1.6 Wing support structure..... | 6 |
| T1.7 Nose cone..... | 6 |
| T1.8 Wheel..... | 6 |
| T1.9 Wheel support system..... | 7 |
| T1.10 Tether line slot..... | 7 |
| T1.11 Tether line guide..... | 7 |
| T1.12 Paint finish and decals..... | 7 |
| T1.13 F1 in Schools™ logo decal..... | 7 |
| T1.14 Hand finishing..... | 7 |
| T1.15 Vertical reference plane..... | 7 |
| T1.16 Official balsa wood blank..... | 8 |
| ARTICLE T2 – GENERAL PRINCIPLES..... | 8 |
| T2.1 Regulations documents..... | 8 |
| T2.2 Interpretation of the regulations..... | 8 |
| T2.3 Amendments to the regulations..... | 8 |
| T2.4 Safe construction..... | 8 |
| T2.5 Compliance with regulations..... | 8 |
| T2.6 Critical technical regulations..... | 9 |
| T2.7 Design ideas and regulation compliance questions..... | 9 |
| T2.8 Measurements..... | 9 |
| ARTICLE T3 – FULLY ASSEMBLED CAR..... | 9 |
| T3.1 Design, manufacture and construction – [Critical regulations]..... | 9 |
| T3.2 Undefined features – [Critical regulation Penalty – 12pts]..... | 10 |
| T3.3 Overall length – [Critical regulation Penalty – 12pts]..... | 10 |
| T3.4 Overall width – [Critical regulation Penalty – 12pts each]..... | 10 |
| T3.5 Overall height – [Critical regulation Penalty – 12pts]..... | 10 |
| T3.6 Total weight – [Critical regulation Penalty – 12pts]..... | 11 |
| T3.7 Body to track distance – [Penalty – 6pts]..... | 11 |
| T3.8 Status during racing - [Penalty – 12pts]..... | 11 |
| ARTICLE T4 – BODY..... | 11 |
| T4.1 Body construction – [Critical regulation Penalty – 12pts]..... | 11 |
| T4.2 Implants and voids – [Critical regulation Penalty – 12pts]..... | 11 |
| T4.3 Virtual cargo – [Critical regulation Penalty – 12pts]..... | 11 |
| T4.4 Body thickness – [Penalty – 6pts each]..... | 12 |
| T4.5 F1 in Schools™ logo decal location – [Penalty – 12pts]..... | 12 |
| ARTICLE 5 - CO2 CYLINDER CHAMBER..... | 13 |
| T5.1 Diameter – [Penalty – 6pts]..... | 13 |
| T5.2 Distance from track surface – [Penalty – 3pts]..... | 13 |

| | | |
|---|--|-----------|
| T5.3 | Depth - [Penalty - 3pts]..... | 14 |
| T5.4 | Thickness of chamber surrounds - [Penalty - 6pts]..... | 14 |
| T5.5 | Finishing of chamber surrounds - [Penalty - 3pts]..... | 14 |
| ARTICLE T6 - TETHER LINE SLOT..... | | 15 |
| T6.1 | Location and length - [Critical regulation Penalty - 12pts]..... | 15 |
| T6.2 | Tether line slot cross-section - [Penalty - 6pts]..... | 15 |
| ARTICLE T7 - TETHER LINE GUIDES..... | | 15 |
| T7.1 | Location - [Critical regulation Penalty - 12pts]..... | 15 |
| T7.2 | Track clearance - [Penalty - 6pts]..... | 15 |
| T7.3 | Diameter - [Penalty - 3pts]..... | 16 |
| T7.4 | Guide separation - [Penalty - 3pts]..... | 16 |
| T7.5 | Tether line guide safety - [Penalty - 6pts]..... | 16 |
| ARTICLE T8 - WHEELS..... | | 16 |
| T8.1 | Number and location - [Critical regulation Penalty - 12pts]..... | 16 |
| T8.2 | Diameter - [Critical regulation Penalty - 12pts]..... | 16 |
| T8.3 | Width - [Critical regulation Penalty - 12pts]..... | 17 |
| T8.4 | Visibility - [Critical regulation Penalty - 12pts]..... | 17 |
| T8.5 | Race track contact - [Penalty - 3pts]..... | 17 |
| T8.6 | Rolling surface - [Penalty - 6pts]..... | 17 |
| T8.7 | Wheel support systems - [Penalty - 6pts]..... | 18 |
| ARTICLE T9 - NOSE CONE..... | | 18 |
| T9.1 | Construction - [Penalty - 12pts]..... | 18 |
| ARTICLE T10 - WING AND WING SUPPORT STRUCTURE..... | | 18 |
| T10.1 | Description and placement - [Critical regulation Penalty - 12pts]..... | 18 |
| T10.2 | Construction - [Critical regulation Penalty - 12pts]..... | 18 |
| T10.3 | Clear airflow - [Critical regulation Penalty - 12pts]..... | 18 |
| T10.4 | Rear wing location - [Critical regulation Penalty - 12pts]..... | 19 |
| T10.5 | Rear wing height - [Critical regulation Penalty - 12pts]..... | 19 |
| T10.6 | Front wing location - [Critical regulation Penalty - 12pts]..... | 19 |
| T10.7 | Visibility of front wing - [Penalty - 6pts]..... | 19 |
| T10.8 | Identification method for scrutineering - [Penalty - 6pts]..... | 19 |
| T10.9 | Front and rear wing span - [Penalty - 6pts each]..... | 20 |
| T10.10 | Span segments - [Penalty - 6pts]..... | 20 |
| T10.11 | Front and rear wing chord - [Penalty - 3pts each]..... | 20 |
| T10.12 | Front and rear wing thickness - [Penalty - 3pts each]..... | 21 |
| APPENDIX - OTHER ILLUSTRATIONS..... | | 22 |
| i. Launch Pod and Finish Gate dimensions..... | | 22 |
| ii. Official balsa blank dimensions..... | | 23 |
| iii Regulations Compliance Drawing..... | | 24 |

PREFACE – SUMMARY OF REVISIONS FOLLOWING 2011 REVIEW

This section provides an overview of all articles that have been revised from the 2011 Technical Regulations.

T1.10 – Definition of tether line slot revised. Slot to be bounded by ‘solid material’, not just ‘body’.

T1.13 – Changes to official F1 in Schools decal appearance. The black border has been removed from the white background decal.

T2.4.1 & T2.4.2 – Car repair penalty revised to 5 points per repair.

T3.4 – Overall Width. Added articles 3.4.1 and 3.4.2. Minimum regulated dimension is now checked between the outside edges of the front or rear wheels, whichever is the widest.

T4.3 – Virtual Cargo. Size reduced to 40mm x 25mm x 8mm. Deleted “The car body must encompass a virtual cargo” and replaced with “The outer car body surface must encompass a virtual cargo”.

T4.4 – Minimum Body Thickness. Deleted 4.4.2, Min Radii. Article 4.4.1 becomes Article 4.4.

T6.1 – Tether line slot minimum length decreased from 120mm to 90mm.

T8.1 – Wheels. Deleted “Opposing wheels must share a common centre axis” and replaced with “Opposing wheels must share a common centre line”

T10.5 – Rear Wing Location. Words “and support structures” removed from drawing. Drawing refined.

T10.9 – Wing Span. Maximum wing span regulation deleted. Drawing annotations updated.

T10.11 – Wing Chord. Deleted “within the minimum span dimensions of a wing” and replaced with “throughout the wings minimum span”

T10.12 – Wing Thickness. Deleted “must exist across the full span of the wing” and replaced with “must exist throughout the wings minimum span”

ARTICLE T1 – DEFINITIONS

T1.1 F1 in Schools car

This is also referred to as 'the car'. Designed and manufactured according to these regulations for the purpose of participating in races on the F1 in Schools™ track at the World Finals event. Powered only by a single gas cylinder containing 8 grams of pressurised CO₂. F1 in Schools cars are designed to travel the 20 metre race distance as quickly as possible, whilst withstanding the forces of launch acceleration, track traversing and physical deceleration after crossing the finishing line.

An F1 in Schools car assembly must only consist of the following components:

- A body (which includes virtual cargo)
- A CO₂ cylinder chamber
- A front wing
- A rear wing
- Wing support structures
- A nose cone
- Wheels
- Wheel support systems
- A tether line slot
- Tether line guides
- Paint finish and decals

Adhesives with no dimensional impact are permissible for joining components.

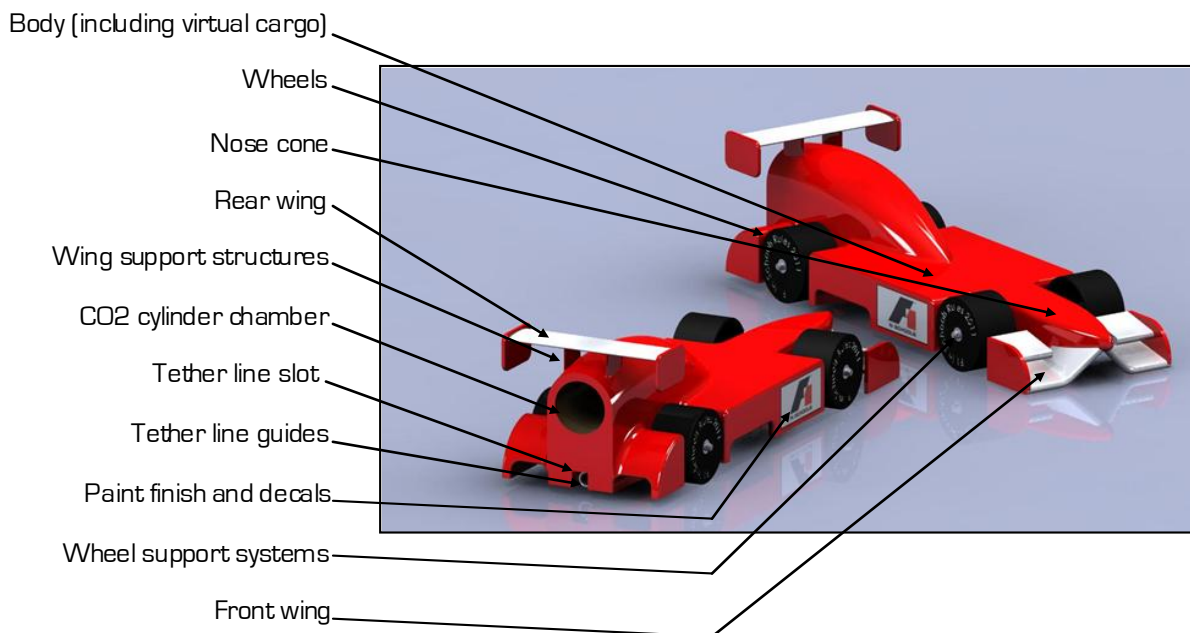

T1.2 Fully assembled car

An F1 in Schools car, without a CO₂ cylinder inserted, presented ready for racing, resting on the track surface, free of any external force other than gravity.

T1.3 Body

The body consists only of balsa wood and is manufactured using one or more CNC machining processes. The body encompasses a virtual cargo and bounds the CO₂ cylinder chamber and all or part of the tether line slot. Any balsa wood material continuing forward

of the front axle centre line is not defined as car body. For dimensional purposes the body also includes any attached decals and surface finishes.

T1.4 CO2 cylinder chamber

A circular cylinder of clear space bounded along its side and one end by car body only. This is where the CO2 gas cylinder is placed for racing.

T1.5 Wing

A wing on an F1 in Schools car is an aerodynamic feature that permits airflow around ALL of its surfaces including its features of a leading and trailing edge. A wing is dimensionally defined by the maximum and minimum span, chord and thickness. The vertical cross-sectional shape of the wing, parallel to the direction of car travel, is referred to as an aerofoil. The following diagram assists with describing relevant aerofoil features.

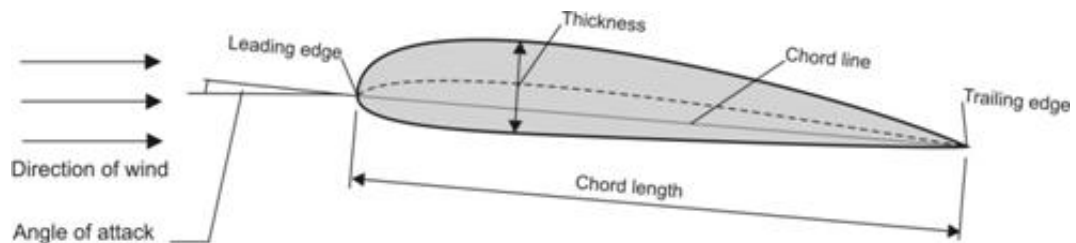

Wing cross-section / aerofoil nomenclature

T1.6 Wing support structure

Is a non-metallic feature, other than wing, car body or nose cone that is joined to a wing surface and may join the wing to any other part of the car assembly.

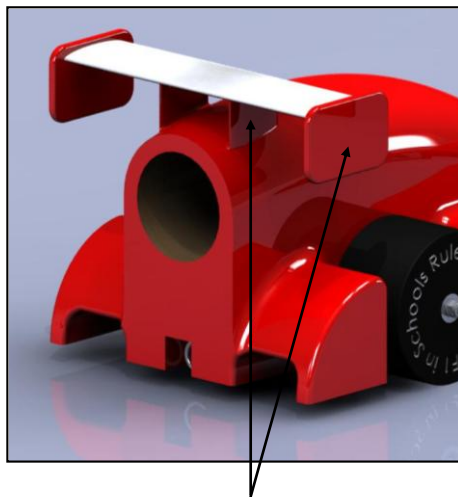

Rear Wing Support Structures

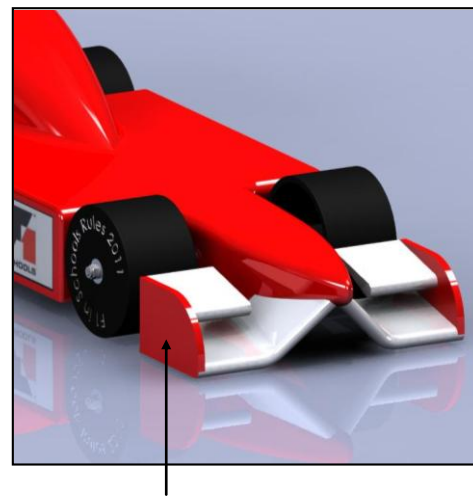

Front Wing Support Structure

T1.7 Nose cone

The nose cone is any non-metallic part of the car, other than wheel, wheel support system, wing or wing support structure, that exists forward of the front axle centre line. This includes any balsa wood material that continues forward from the body.

T1.8 Wheel

A wheel is a single part or assembly of components, cylindrical in form, with its maximum circumference contacting the track surface to enable motion of the car. All material existing within the volume of the extreme diameter and width is considered to be part of the wheel.

T1.9 Wheel support system

Wheel support systems are single parts or an assembly of components that connect a wheel to any other part of the car. These may consist of a combination of manufactured or commercial parts. I.e. Bearings, bushes and axles could be used.

T1.10 Tether line slot

The tether line slot is a rectangular prism of clear space that is bounded by solid material on three sides of its length.

T1.11 Tether line guide

A tether line guide is a key safety component which completely surrounds the track tether line so as to safely connect the car to the tether line during races. A tether line guide can be a component sourced from a supplier or manufactured wholly or in part by the team.

T1.12 Paint finish and decals

A paint finish on an F1 in Schools car is considered to be any visible surface covering on any component of the car. A decal is thin material adhered to a component or paint finish surface. To be defined as a decal, 100% of the adhering side must be attached to a surface.

T1.13 F1 in Schools™ logo decal

The official F1 in Schools™ logo decal consists of the F1 in Schools™ logo graphic printed on either black or white adhesive vinyl with a horizontal dimension of 30mm and vertical dimension of 15mm. The official decals are supplied by F1 in Schools Ltd at event registration. Teams choose whether to use black or white background decals. A team can manufacture their own decals, provided they are correct in size, colour and graphic design.



Decal design with black background.

T1.14 Hand finishing

Hand finishing is defined as use of a hand powered device (e.g. abrasive paper) for removing only the irregularities that may remain on a CNC machined surface of the car body. These irregularities are often referred to as 'scalloping marks'.

T1.15 Vertical reference plane

To assist with describing dimensions, it is assumed that an invisible plane exists two dimensional along the length of the CO₂ cylinder chamber centre axis and perpendicular to the track surface. This is known as the vertical reference plane.

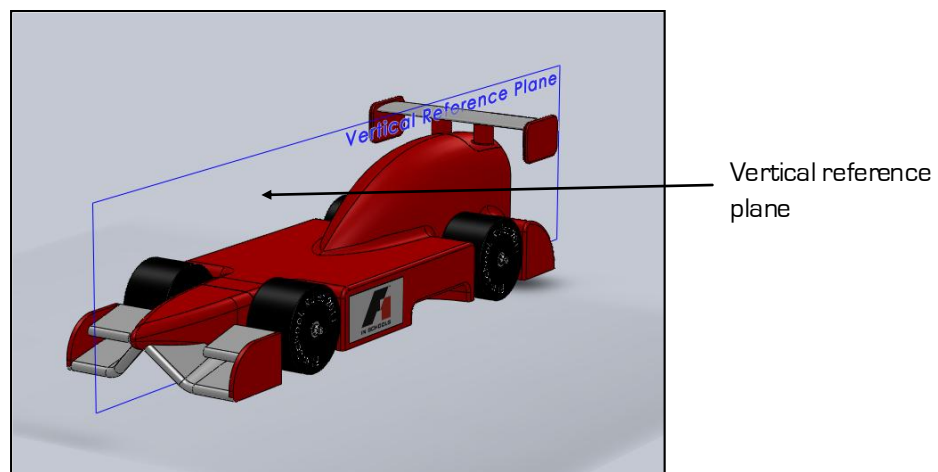

T1.16 Official balsa wood blank

The official balsa wood blank is a homogenous piece of forested balsa wood, processed to the dimensional features as shown by diagrams in the appendix of this document.

ARTICLE T2 – GENERAL PRINCIPLES

T2.1 Regulations documents

T2.1.1 F1 in Schools Ltd. issues the regulations, their revisions and amendments made.

T2.1.2 Technical Regulations - This document. The Technical Regulations document is mainly concerned with those regulations that are directly related to F1 in Schools car design and manufacture. Technical Regulation article numbers have a 'T' prefix

T2.1.3 Competition Regulations - A document separate to this one which is mainly concerned with regulations and procedures directly related to judging and the competition event. Competition Regulation article numbers have a 'C' prefix

T2.2 Interpretation of the regulations

T2.2.1 The final text of these regulations is in English should any dispute arise over their interpretation. The text of a regulation, diagrams and any related definitions should be considered together for the purpose of interpretation.

T2.2.2 Text clarification - Any questions received that are deemed by F1 in Schools Ltd. to be related to regulation text needing clarification will be answered by F1 in Schools Ltd. The question received, along with the clarification provided by F1 in Schools Ltd., will be published to all competing teams at the same time.

T2.3 Amendments to the regulations

Any amendments will be announced and released by F1 in Schools Ltd. by email notification to all in-country co-ordinators as well as being posted on the website www.f1inschools.com. Any amended text will be indicated thus (using red underlined text)

T2.4 Safe construction

T2.4.1 Specification judging - All submitted cars will be inspected closely to ensure that they are engineered and constructed safely for the purpose of racing. High importance is placed on ensuring that tether line guides are robust and secure. If the Judges rule an aspect of the primary race car to be unsafe for racing, the team will be required to use their back-up race car. If the back-up race car is also ruled to be unsafe, repairs / modifications can be carried out on the primary race car. Any such repair work or change of car will result in a penalty of 5 points.

T2.4.2 During racing - The race Officials will routinely inspect cars for safety during scheduled races. If the Officials rule a car to be unsafe, the back-up race car will be used and a penalty of 5 points will be imposed. The team may repair the primary race as per the Competition Regulations, Article C9 - Car Repairs and Servicing.

T2.5 Compliance with regulations

Points will be deducted for non-compliance with the technical regulations as per the specification judging score card. Both the primary and back-up race cars are scrutineered and points will be deducted for any infringements on either car. These penalties are only imposed once, per infringement, per car. Several regulations have been identified as 'critical regulations'.

T2.6 Critical technical regulations

T2.6.1 Regulations identified as a critical technical regulation are listed in this article. If a team's primary race car is judged as being NON-COMPLIANT with any critical technical regulation they will be INELIGIBLE for the following awards:

- World Champions
- Fastest Car
- Best Engineered Car

T2.6.2 If the back-up race car is used for any races, it must also comply with all critical technical regulations for the team to be eligible for these awards.

T2.6.3 The critical technical regulations are articles:

T3.1 / T3.2 / T3.3 / T3.4 / T3.5 / T3.6 / T4.1 / T4.2 / T4.3 / T6.1 / T7.1 / T8.1 / T8.2 / T8.3 / T8.4 / T10.1 / T10.2 / T10.3 / T10.4 / T10.5 / T10.6

T2.7 Design ideas and regulation compliance questions.

Teams are not permitted to seek a ruling from F1 in Schools Ltd. or any competition officials or judges before the event as to whether a design idea complies with these regulations. Rulings will only be made by the Judges at the World Finals event. Design compliance to the regulations forms part of the competition. As in Formula 1™ innovation is encouraged, and F1 in Schools™ teams may also find, sometimes controversial ways, of creating design features that push the boundaries of the regulations in order to get an extra competitive edge.

T2.8 Measurements

T2.8.1 Tolerance when measuring all dimensions is +/-0.1mm unless otherwise stated.

T2.8.2 Tolerance when measuring weight is +/-0.5grams.

T2.8.3 Dimensional measures - All car component dimensions are inclusive of any applied paint finish or decal. A series of specially manufactured gauges will be used to broadly verify dimensional compliance. Accurate measuring tools, such as vernier callipers, will then be used to closely inspect any dimensions found to be close to the dimensional limits per the initial gauge inspection.

T2.8.4 Weight measures - all weight measurements will be made using the F1 in Schools Ltd. electronic competition scales which are accurately calibrated to +/- 0.1 gram

ARTICLE T3 - FULLY ASSEMBLED CAR

T3.1 Design, manufacture and construction - [Critical regulations]

T3.1.1 Design - All F1 in Schools™ cars must be designed and engineered using CAD (Computer Aided Design) and CAM (Computer Aided Manufacture) technology. CAD software used should provide for 3D part modelling, assembly and 3D realistic rendering. We recommend teams use Solid Works for CAD. The CAM package should allow students to simulate CNC machining processes so they can show evidence of these in their portfolio. We recommend the use of DENFORD QuickCAM PRO software.

T3.1.2 Manufacture - The body of all F1 in Schools™ cars must be manufactured via material removal using a CNC router/ milling machine. We recommend all teams use a DENFORD CNC router. This manufacturing process should occur at your school/college or at a designated manufacturing centre/partner site.

T3.1.3 Hand finishing of the car body is permitted. Refer ARTICLE 1.14

T3.1.4 Paint finish - Each car body should feature a high quality paint finish.

T3.1.5 The primary and back-up race cars must have identically designed components.

T3.2 Undefined features - [Critical regulation | Penalty - 12pts]

The car assembly must only consist of components listed in ARTICLE 1.1.

T3.3 Overall length - [Critical regulation | Penalty - 12pts]

This is measured parallel to the track surface and vertical reference plane, between the front and rear extremities of the assembled car.

Min: 170mm / Max: 210mm



T3.4 Overall width - [Critical regulation | Penalty - 12pts each]

T3.4.1 Maximum assembled car width, measured normal to the vertical reference plane, between the outside edges of the widest feature of the car assembly.

Max: 85mm

T3.4.2 Minimum assembled car width, measured normal to the vertical reference plane, between outside edges of the front or rear wheels, whichever is widest.

Min: 60mm

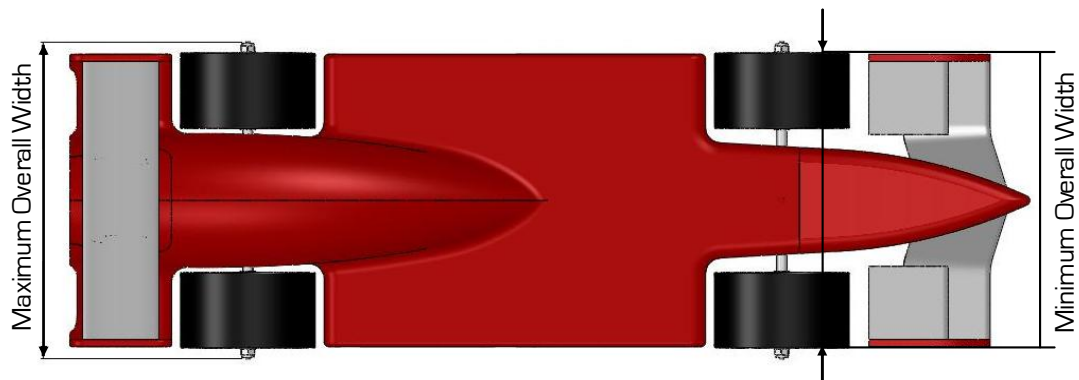

T3.5 Overall height - [Critical regulation | Penalty - 12pts]

Maximum assembled car height, measured normal to the track surface.

Max: 60mm.

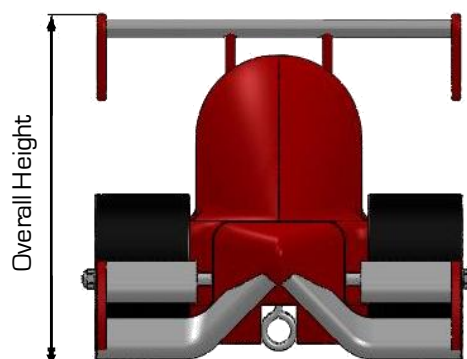

T3.6 Total weight - [Critical regulation | Penalty - 12pts]

Total weight is the weight of the car excluding a CO2 gas cylinder. If ruled underweight, ballast will be added before racing, at 2 grams for every gram under weight.

Min: 55.0grams.

T3.7 Body to track distance - [Penalty - 6pts]

Measured normal from the track surface to any part of the underside of the car body that exists between the front and rear axle centre lines, no part can be 'lower' than the minimum or 'higher' than the maximum.

Min: 3mm / Max: 15mm

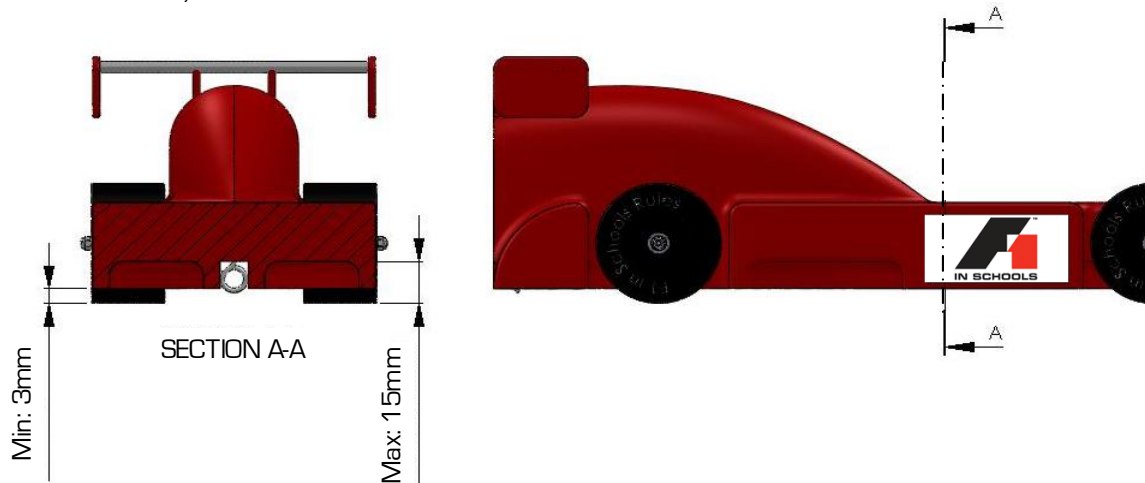

T3.8 Status during racing - [Penalty - 12pts]

The car assembly must be designed so that no items other than CO2 cylinders are removed, replaced or added to the assembly during scheduled race events..

ARTICLE T4 - BODY

T4.1 Body construction - [Critical regulation | Penalty - 12pts]

The car body must be CNC machined from a single official balsa blank.

T4.2 Implants and voids - [Critical regulation | Penalty - 12pts]

No implants or hidden voids are permitted in the car body

T4.3 Virtual cargo- [Critical regulation | Penalty - 12pts]

The outer car body surface must encompass a virtual cargo measuring a minimum of 25mm x 40mm x 8mm to be wholly positioned between the front and rear axle centre lines. When viewed from the front the virtual cargo must be 40mm wide. The location of the virtual cargo should be identified on the submitted orthographic drawings.

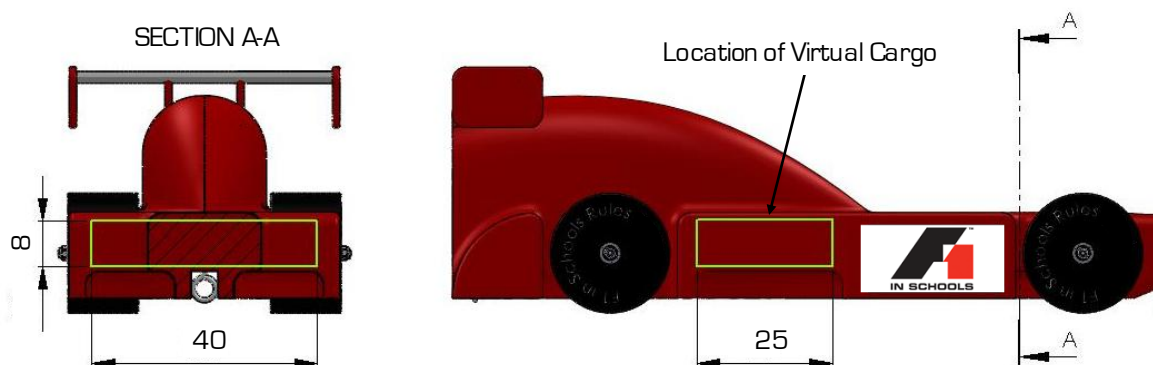

T4.4 Body thickness – [Penalty – 6pts]

No part of the body is allowed to be less than 3mm thick.

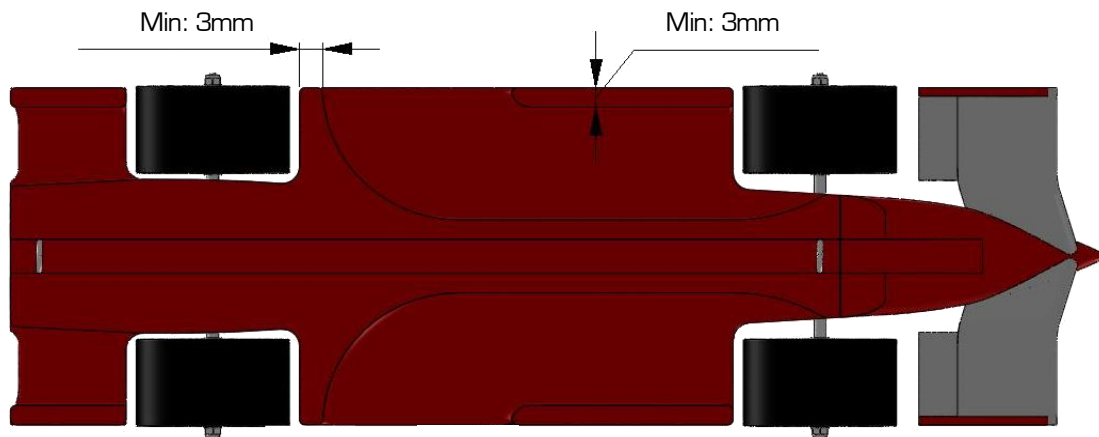

T4.5 F1 in Schools™ logo decal location – [Penalty – 12pts]

A surface of car body measuring no less than 30mm wide x 15 mm high must be visible in each side elevation, between the front and rear wheels **AND OUTSIDE** of the virtual cargo **WIDTH**. The F1 in Schools™ logo decal must be located within this area before cars are submitted. Teams should choose to use the decal type, (black or white background), that provides the greatest contrast against the colour the decal is to be adhered to.

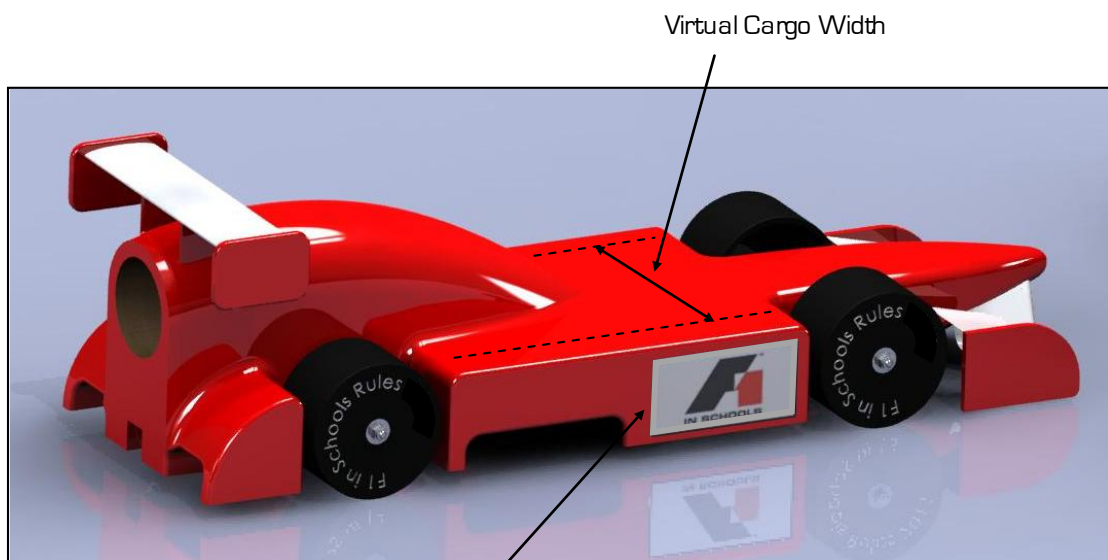

A surface Min: 30mm x 15mm when measured in the side view

ARTICLE 5 - CO2 CYLINDER CHAMBER

T5.1 Diameter - [Penalty - 6pts]

CO2 cylinder chamber diameter, measured at any point through its depth.

Min: 19.5mm +/- 0.5mm

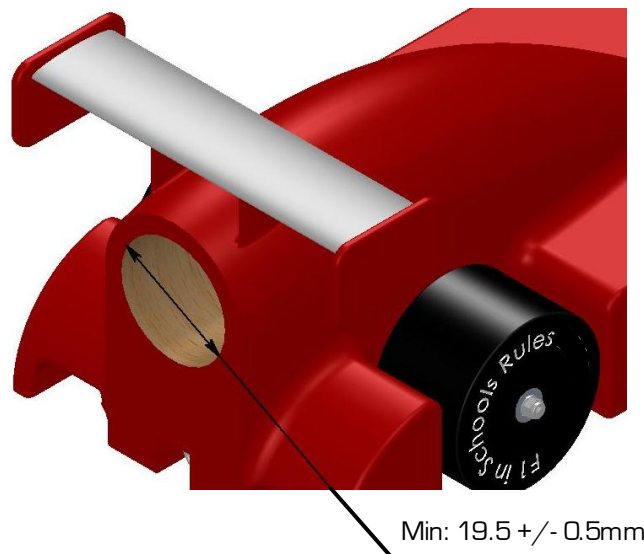

T5.2 Distance from track surface - [Penalty - 3pts]

Lowest point of the chamber opening to the track surface, measured normal to the track surface.

Min: 22mm / Max: 30mm

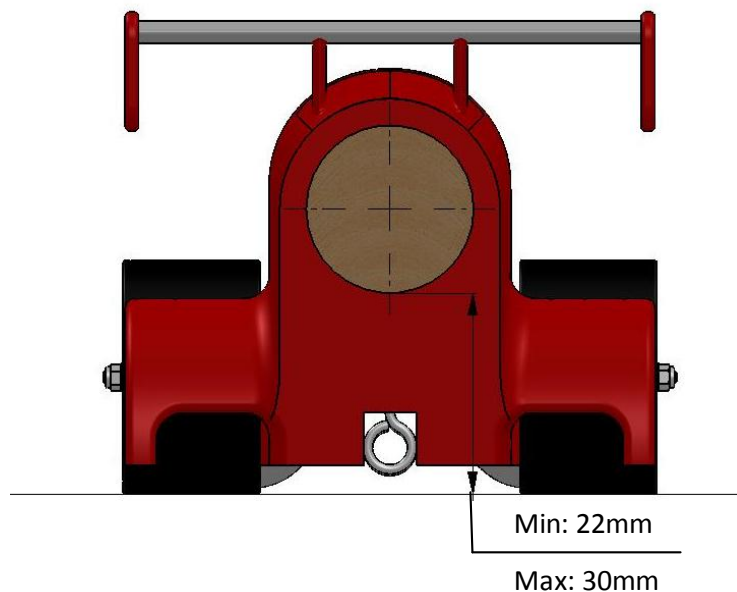

T5.3 Depth – [Penalty – 3pts]

Depth of chamber measured parallel to the vertical reference plane anywhere around the chamber circumference from opening to chamber end.

Min: 50mm / Max: 60mm

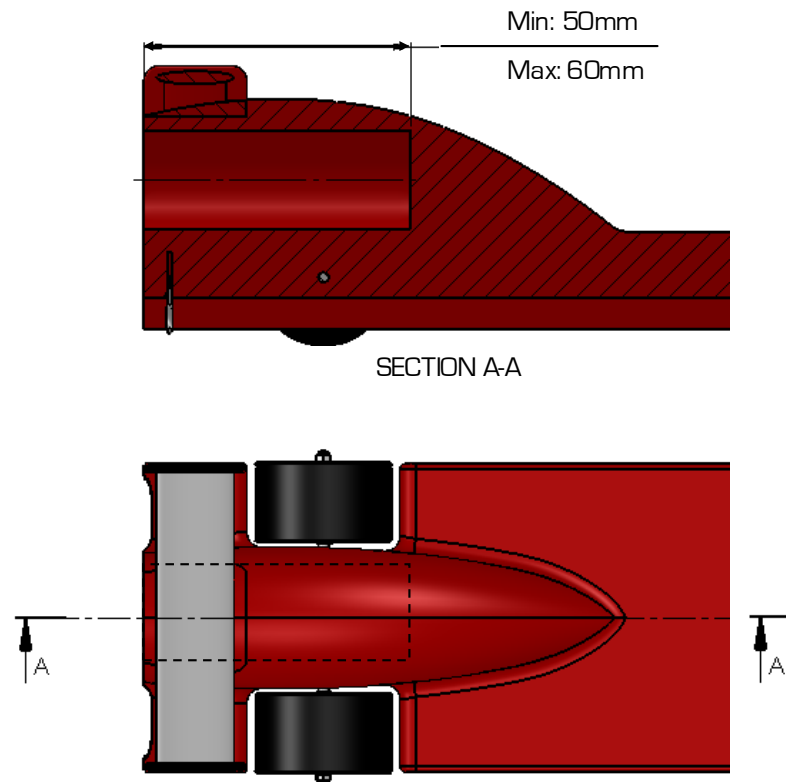
**T5.4 Thickness of chamber surrounds** – [Penalty – 6pts]

The CO₂ cylinder chamber must be surrounded by car body only. Chamber surrounds below the minimum thickness may be considered a safety issue, refer ARTICLE 2.4. Thickness is measured through any line of the chamber radius.

Min: 3mm

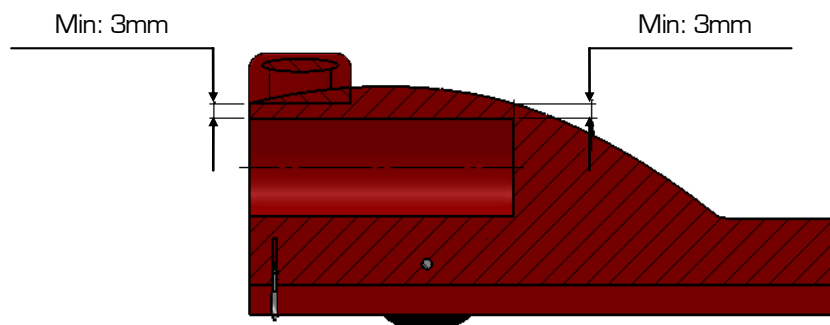
**T5.5 Finishing of chamber surrounds** – [Penalty – 3pts]

The inside surface must be free of any paint finish or decals.

ARTICLE T6 – TETHER LINE SLOT

T6.1 Location and length – [Critical regulation | Penalty – 12pts]

A tether line slot must exist continuously along the centre of the underside of the assembled car. Measured parallel to the track surface and vertical reference plane.

Min: 90mm

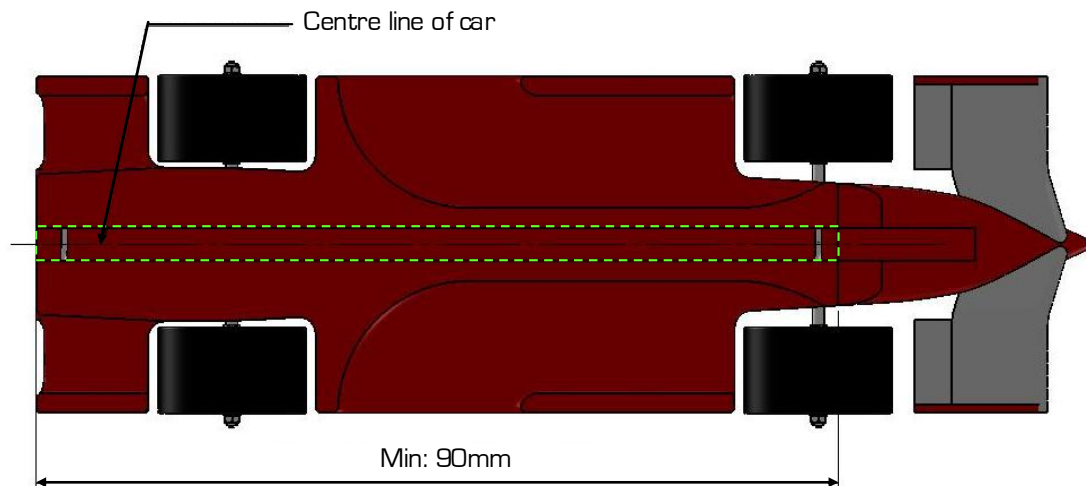

T6.2 Tether line slot cross-section – [Penalty – 6pts]

The tether line slot must be square in cross-section. Each side of the square measured normal to the track and vertical reference plane.

Min: 6mm +/- 1.0mm

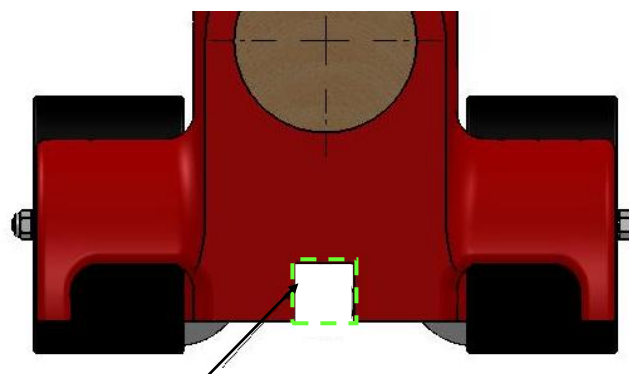

Square cross-section Min: 6mm +/- 1.0mm

ARTICLE T7 – TETHER LINE GUIDES

T7.1 Location – [Critical regulation | Penalty – 12pts]

Each car must have two (2) tether line guides firmly secured, one toward the front and one toward the rear of the car. The tether line must pass through both tether line guides during racing.

T7.2 Track clearance – [Penalty – 6pts]

As part of the fully assembled car, the tether line guides must not make contact with the racing surface.

T7.3 Diameter – [Penalty – 3pts]

Referring to the hole within the guide which the tether line passes through, diameter
Min: 3mm / Max: 5mm

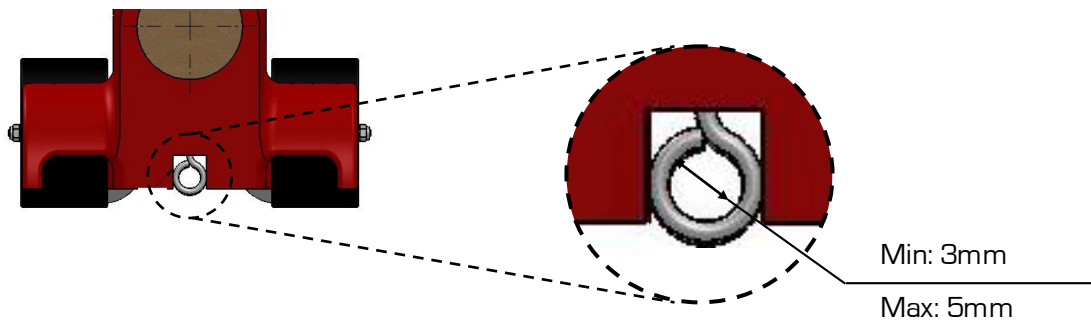
**T7.4 Guide separation** – [Penalty – 3pts]

The shortest distance between the inside edges of the guides, measured parallel to the track surface and vertical reference plane.

Min: 120mm / Max: 190mm

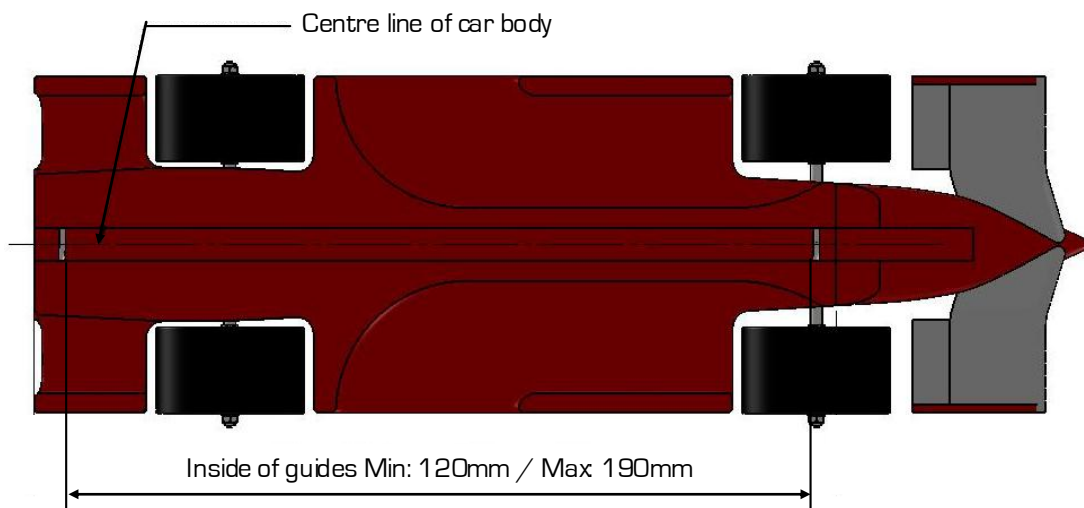
**T7.5 Tether line guide safety** – [Penalty – 6pts]

Guide holes must be completely closed to prevent the tether line from slipping out during racing. The construction of the tether line guides must be robust so as to prevent the diameter or shape changing during racing.

ARTICLE T8 – WHEELS**T8.1 Number and location** – [Critical regulation | Penalty – 12pts]

The car assembly must include 4 cylindrical wheels, two at the front and two at the rear. Opposing wheels must share a common centre line.

T8.2 Diameter – [Critical regulation | Penalty – 12pts]

Wheel diameter measured to the rolling surface
Min: 26mm / Max: 34mm

T8.3 Width - [Critical regulation | Penalty - 12pts]

Wheel width measured along the rolling surface contact line
 Min: 15mm / Max: 19mm

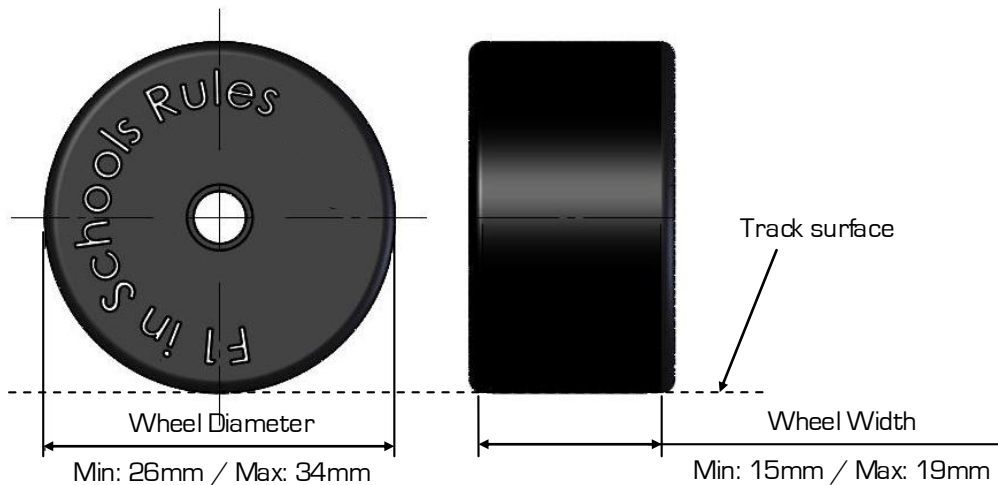

T8.4 Visibility - [Critical regulation | Penalty - 12pts]

The wheels are not allowed to be inside the car body and the wheel view cannot be obscured in any way, in the cars top and side elevation views.

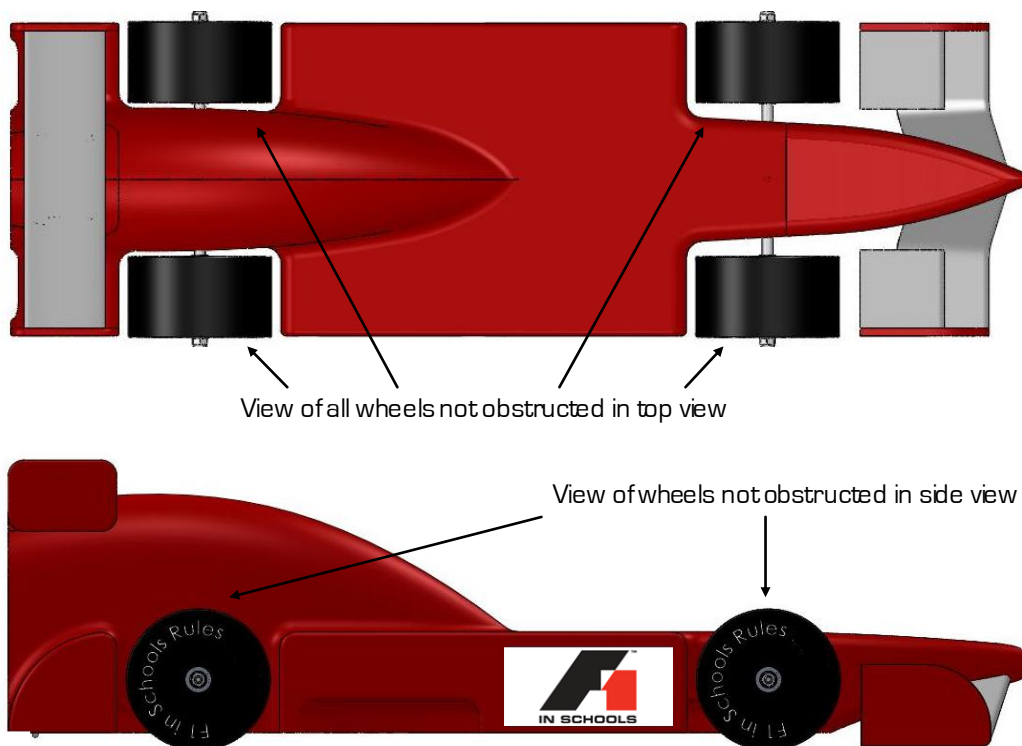

T8.5 Race track contact - [Penalty - 3pts]

All 4 wheels must touch the racing surface at the same time across the full width of the wheel, assuming a tolerance of $\pm 0.1\text{mm}$

T8.6 Rolling surface - [Penalty - 6pts]

The wheel diameter must be consistent across the whole rolling surface.

T8.7 Wheel support systems - [Penalty - 6pts]

Wheel support systems may only exist within the cylindrical volume generated through the maximum diameter of two opposing wheels.

ARTICLE T9 - NOSE CONE

T9.1 Construction - [Penalty - 12pts]

The nose cone can be manufactured from any non-metallic material

ARTICLE T10 - WING AND WING SUPPORT STRUCTURE

T10.1 Description and placement - [Critical regulation | Penalty - 12pts]

The design of the car should resemble an actual F1 car through the inclusion of a wing on the front nose of the car and a wing at the rear of the car. Each wing must have a leading edge and a trailing edge. Refer to definition at ARTICLE 1.5.

T10.2 Construction - [Critical regulation | Penalty - 12pts]

The front wing, rear wing and any support structures may be manufactured from a separate non-metallic material. The wing chord and span dimensions must remain unchanged during races. I.e. Wings must be rigid, ruled at the Judge's discretion.

T10.3 Clear airflow - [Critical regulation | Penalty - 12pts]

A wing surface must have a minimum of 3mm of clear 'air' space completely surrounding it, measured normal to the wing surface to any other part of the car.

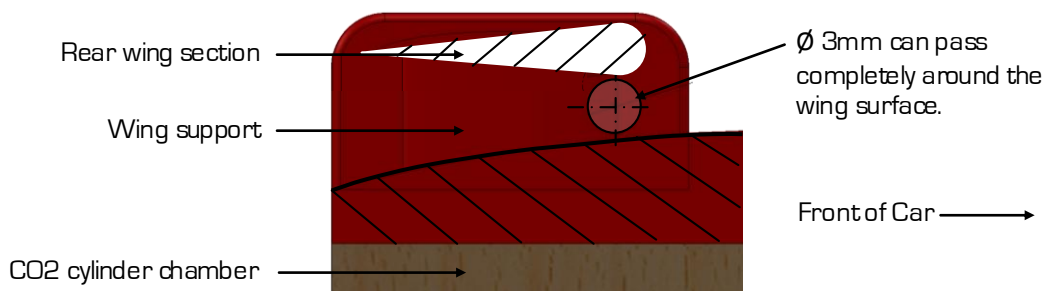

Example of 3mm clear airflow around wing surface.
Rear wing cross-section.

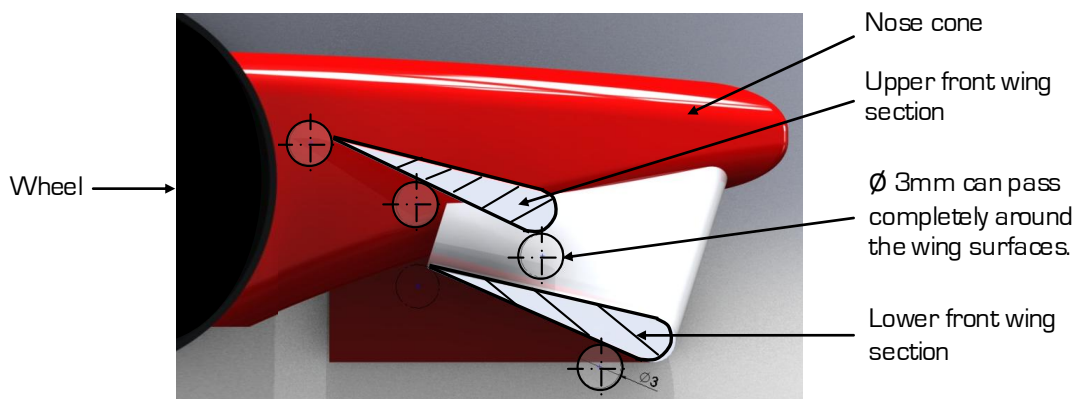

Example of 3mm clear airflow around wing surface
Front wing cross-section

T10.4 Rear wing location – [Critical regulation | Penalty – 12pts]

The whole of the rear wing and any support structure must be behind the centre line of the rear wheel when viewed in the side elevation.

T10.5 Rear wing height – [Critical regulation | Penalty – 12pts]

The bottom surface of the rear wing must be higher than the highest point of the rear wheel when measured normal to the track surface.

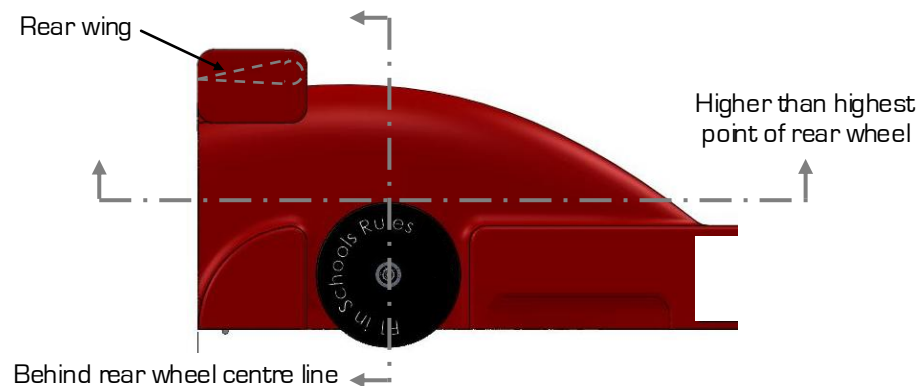
T10.6 Front wing location – [Critical regulation | Penalty – 12pts]

The whole of the front wing and any support structure must be in front of the centre line of the front wheel when viewed in the side elevation.

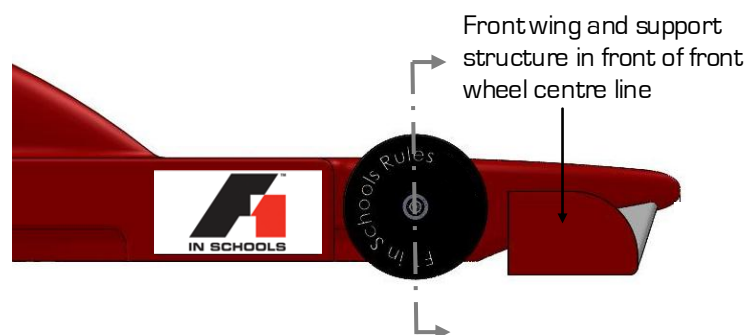
T10.7 Visibility of front wing – [Penalty – 6pts]

Visibility of the front wing must not be obstructed by any other component when viewed in the front elevation.

T10.8 Identification method for scrutineering – [Penalty – 6pts]

To assist with scrutineering - the surfaces defining both the front and rear wings **MUST** either be identified clearly on the orthogonal drawing submitted for specification judging, **OR** painted in a different colour from the rest of the surrounding car.

T10.9 Front and rear wing span - [Penalty - 6pts each]

Where the wing span is intersected by another part of the car, the total span is the sum of each segment. The wing span is measured on the top or bottom surface of the wing, whichever is shortest, parallel to track surface and normal to the vertical reference plane.

T10.9.1 Front wing span - Min: 40mm

T10.9.2 Rear wing span - Min 40mm

T10.9.2 - Minimum Rear wing span = E+G

T10.10 - E and G each measure at least 20mm

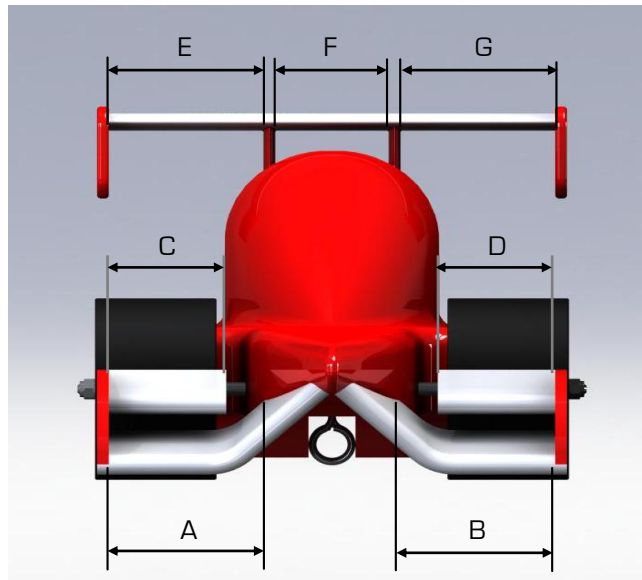

T10.9.1 - Minimum Front wing span = A+B

T10.10 - A and B each measure at least 20mm

T10.10 Span segments - [Penalty - 6pts]

The span of a wing can be intersected by the car body, nose cone or wing support structure to form span segments. All span segments must conform to the wing chord and thickness regulations. At least two (2) of the segments must be of the minimum size.

Min segment size: 20mm

T10.11 Front and rear wing chord - [Penalty - 3pts each]

The wing chord minimum and maximum dimensions must exist throughout the wings minimum span. The chord is the distance between the leading edge and trailing edge measured parallel to the vertical reference plane.

T10.11.1 Front wing chord - Min: 15mm / Max: 25mm

T10.11.2 Rear wing chord - Min 15mm / Max 25mm

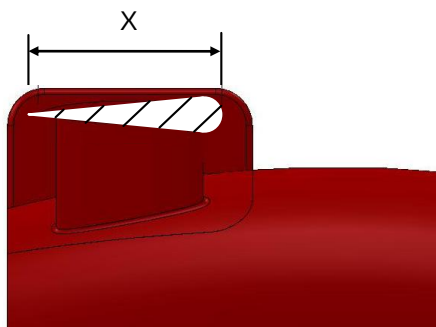

X = Rear wing chord

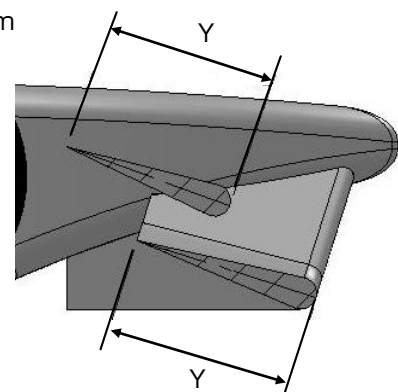

Y = Front wing chord

T10.12 Front and rear wing thickness - [Penalty - 3pts each]

The wing thickness minimum and maximum dimensions must exist throughout the wings minimum span, measured perpendicular to the chord line.

T10.12.1 Front wing thickness - Min: 1.5mm / Max: 6mm

T10.12.2 Rear wing thickness - Min 1.5mm / Max 6mm

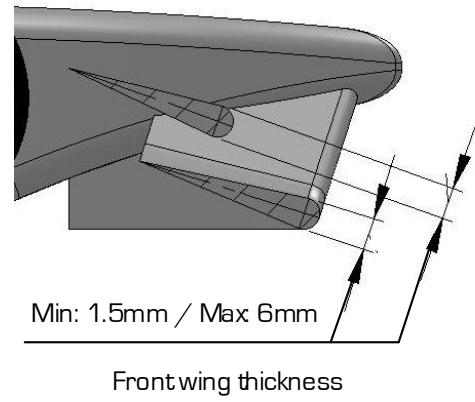
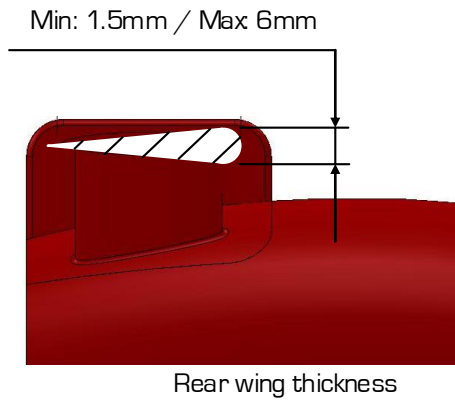

APPENDIX – OTHER ILLUSTRATIONS

i. Launch Pod and Finish Gate dimensions

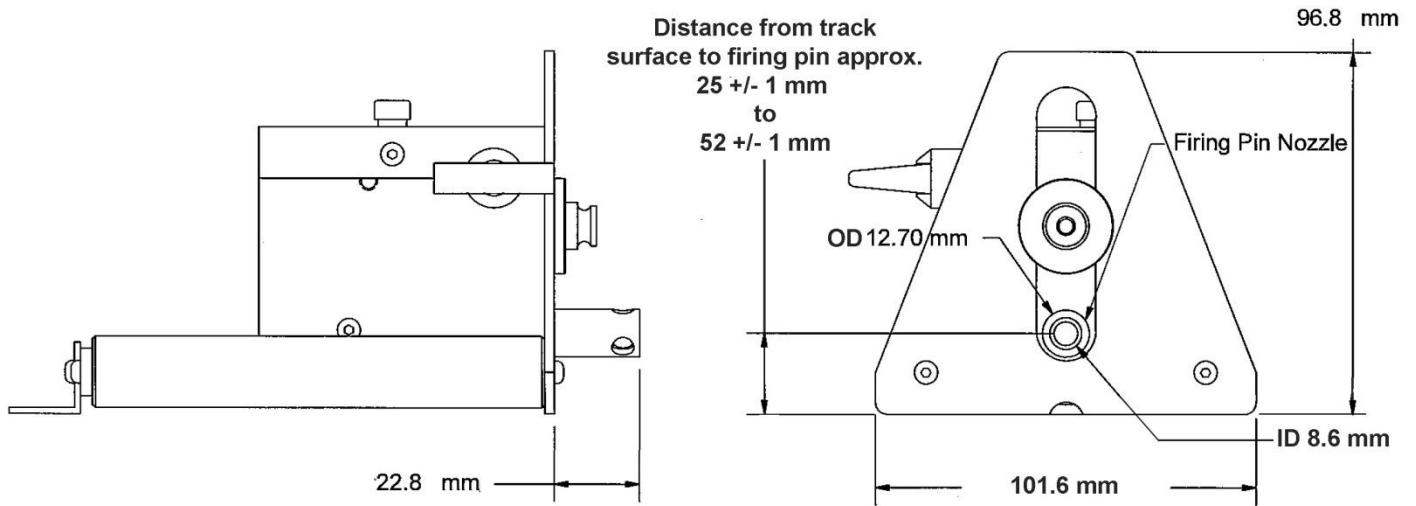

Launch Pod Side and Front Views

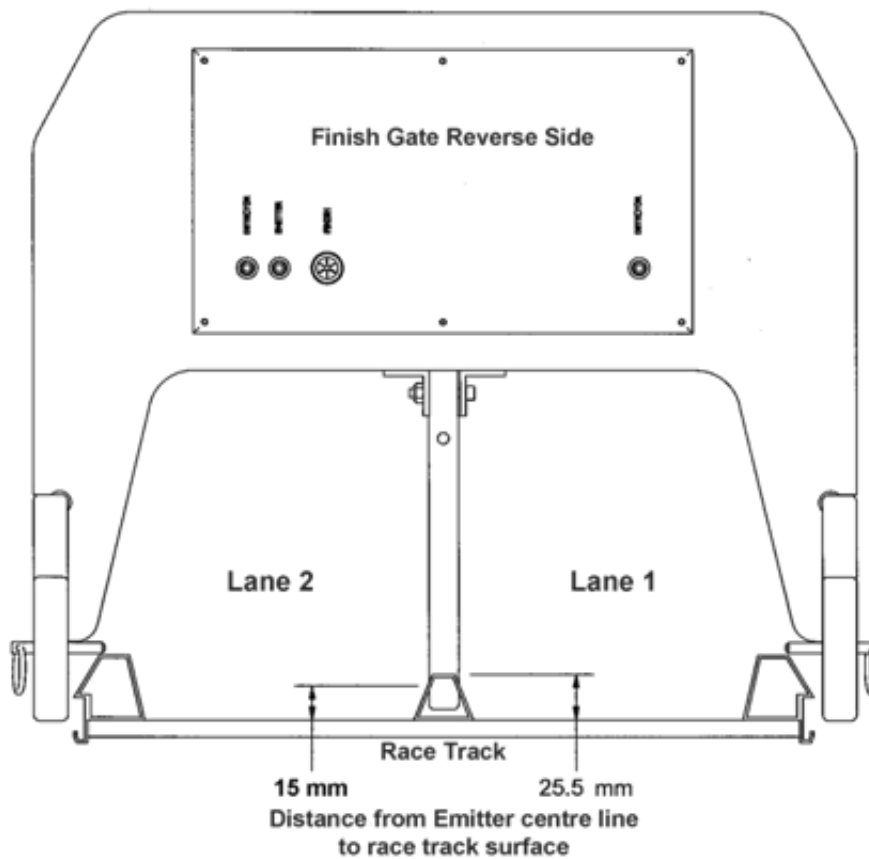

Finish Gate and Race Track section view from rear

ii. Official balsa blank dimensions

Right: 3D rendering of balsa blank



Below: Orthographic projection of balsa blank. All dimensions shown in millimetres

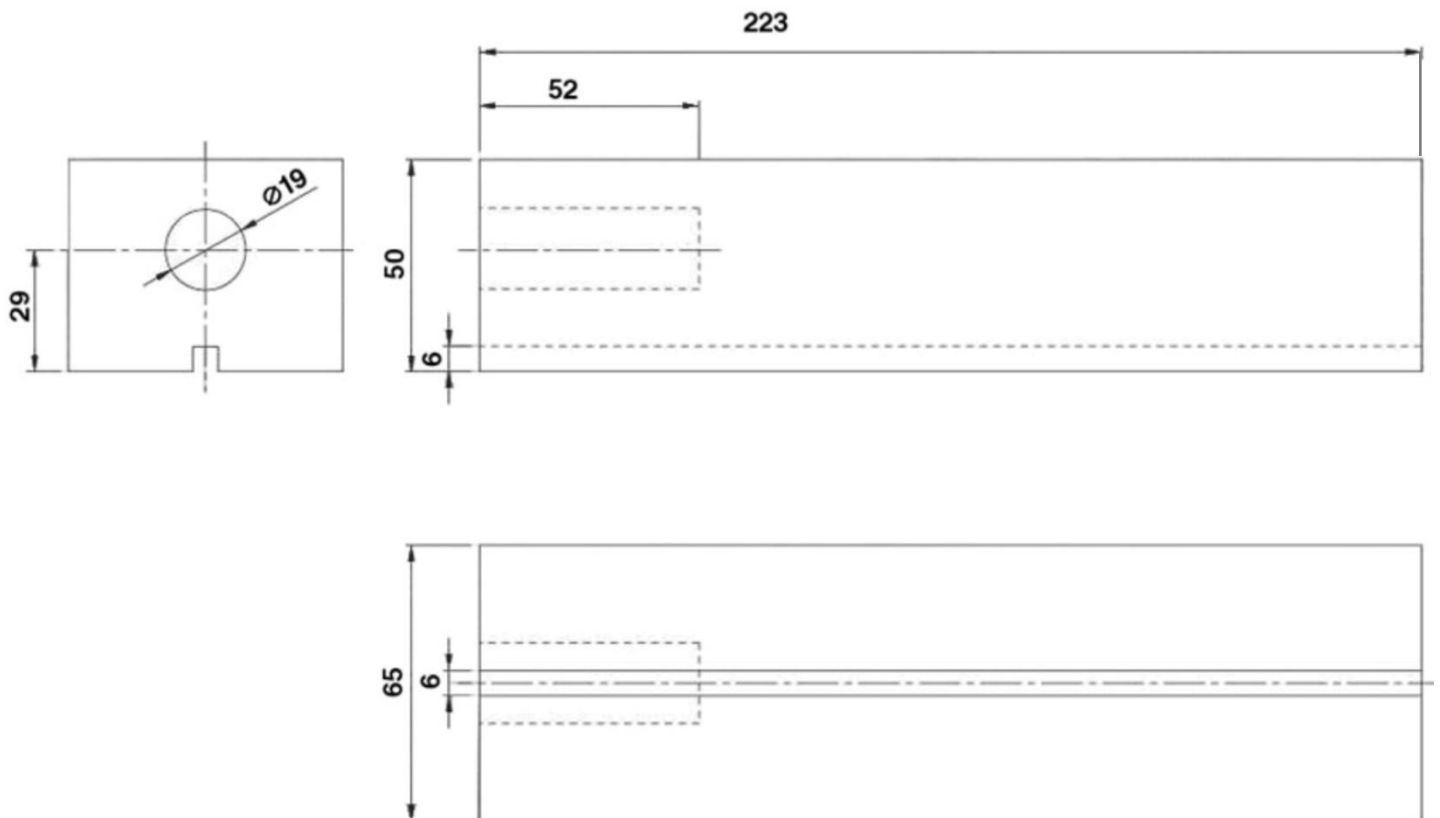

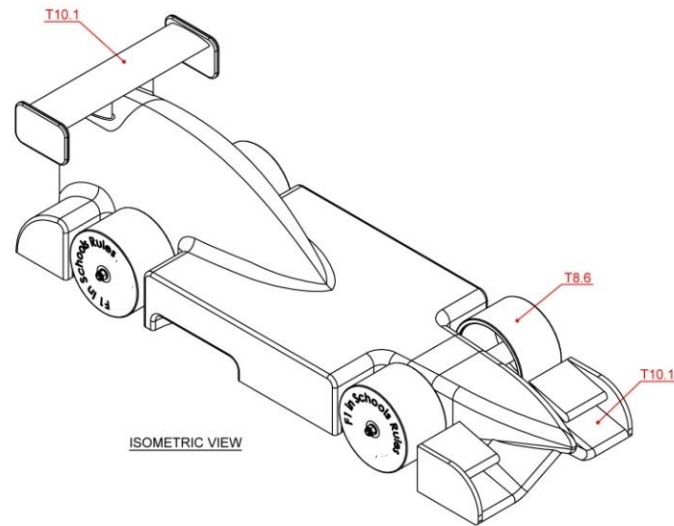

T 10.9.2 - Rear Wing Span
E + G = Minimum 40mm

T 10.9.1 - Front Wing Span
A + B = Minimum 40mm

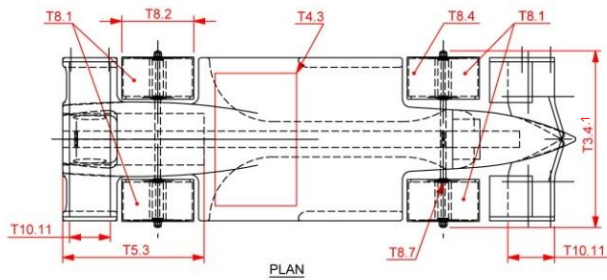
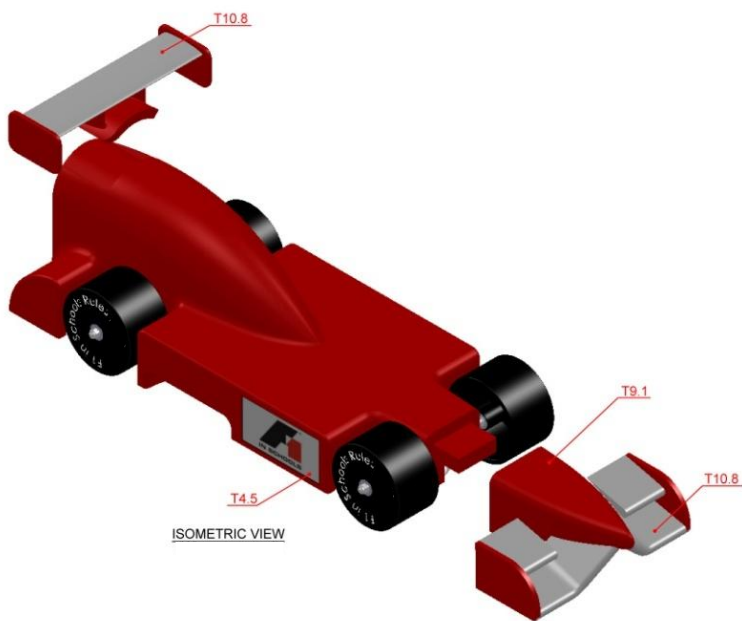
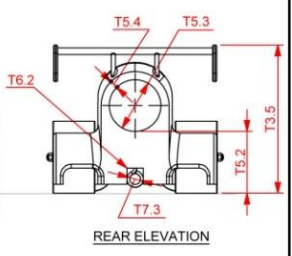
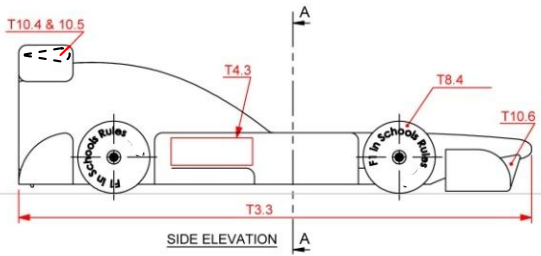
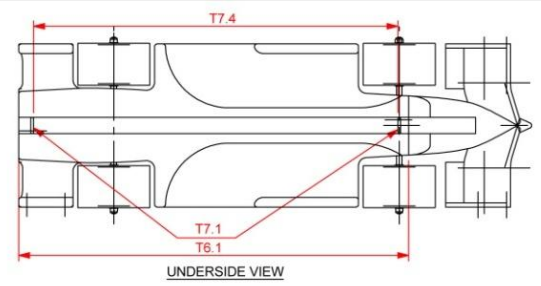
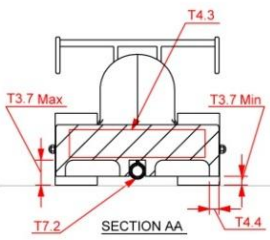
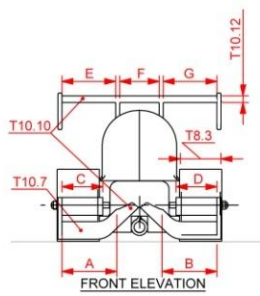

REGULATION COMPLIANCE DRAWING

F1 IN SCHOOLS 2012 WORLD FINALS

Note:
This drawing is for descriptive purposes only. The various car features are shown with corresponding regulation numbers. The car shown does not necessarily comply with all regulations.

| | |
|--------------|-------------|
| Drawn By: WM | Version: 12 |
|--------------|-------------|